

# Quick-Lift Arm

QLAC 75i

**Intelligent lifting device which meets the highest standards of ergonomics, working environment, safety and efficiency.**

Optimized to use in a high hygiene environment with daily cleaning, e.g. food industry.

Easy to use, thanks to outstanding responsiveness and light triple hinged arm of anodized aluminum.

Integrated electrical and mechanical swivel to minimize maintenance and simplify use.

The best auto balance available regardless of load weight.

High cost efficiency through low power consumption, high reliability and long durability.

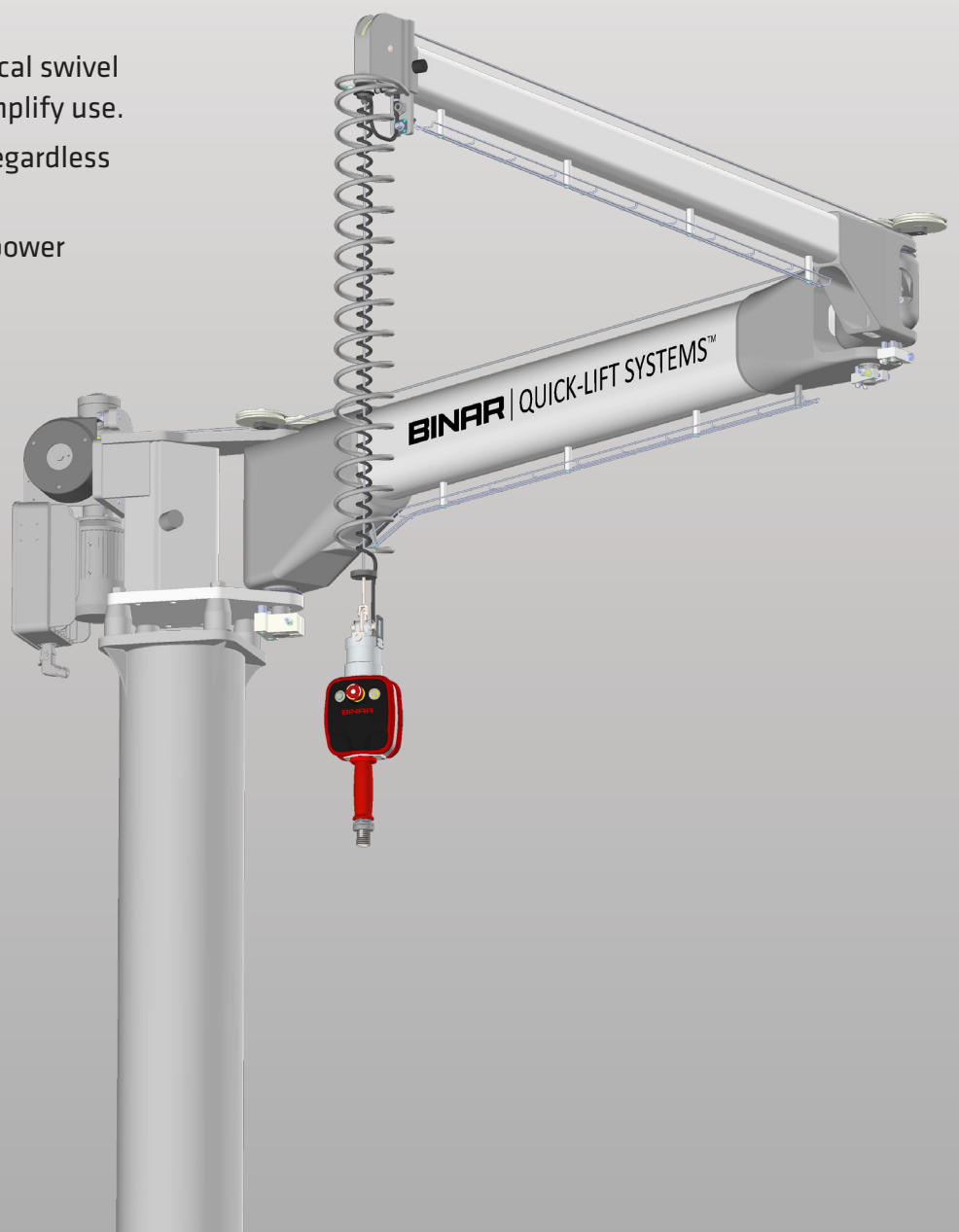

UK distributor

 **Andron  
Handling**  
[www.andronhandling.com](http://www.andronhandling.com)

**BINAR**  
*Improving your productivity*

# Quick-Lift Arm

# QLAC 75i

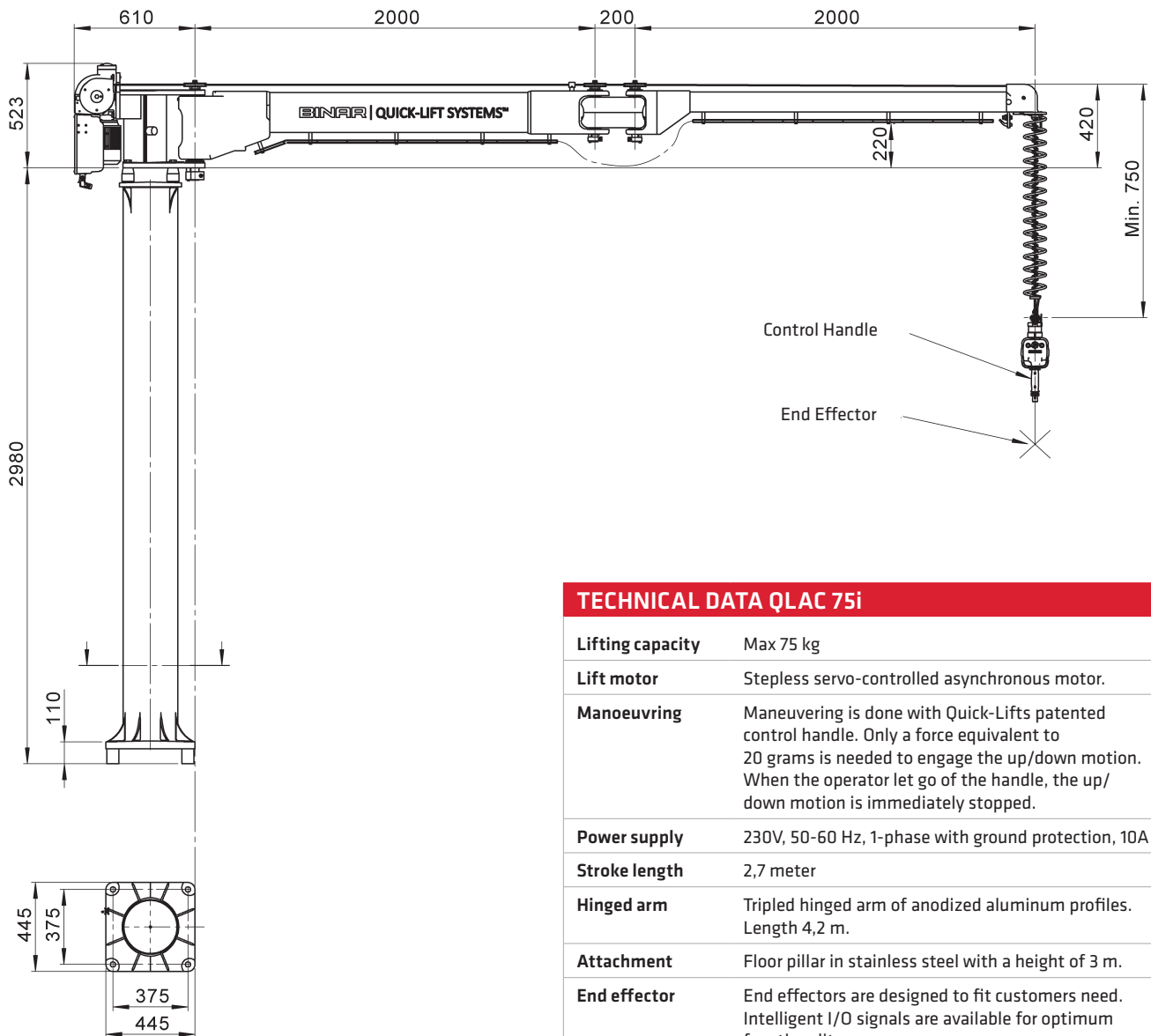

## TECHNICAL DATA QLAC 75i

<b>Lifting capacity</b>	Max 75 kg
<b>Lift motor</b>	Stepless servo-controlled asynchronous motor.
<b>Manoeuvring</b>	Maneuvering is done with Quick-Lifts patented control handle. Only a force equivalent to 20 grams is needed to engage the up/down motion. When the operator let go of the handle, the up/down motion is immediately stopped.
<b>Power supply</b>	230V, 50-60 Hz, 1-phase with ground protection, 10A
<b>Stroke length</b>	2,7 meter
<b>Hinged arm</b>	Tripled hinged arm of anodized aluminum profiles. Length 4,2 m.
<b>Attachment</b>	Floor pillar in stainless steel with a height of 3 m.
<b>End effector</b>	End effectors are designed to fit customers need. Intelligent I/O signals are available for optimum functionality.
<b>Daily care</b>	Drive unit withstanding daily wash down and environments with temperatures up to 50° Celcius and a relative humidity of 80%. Handle and load cell box to be covered and protected against direct flushing. Detailed wash down instructions to be evaluated for each specific application. Use approved detergents for soft material. Check with your supplier.

Binar Quick-Lift Systems AB disclaims responsibility for any errors or incomplete information in the published material and reserves the right to make changes.

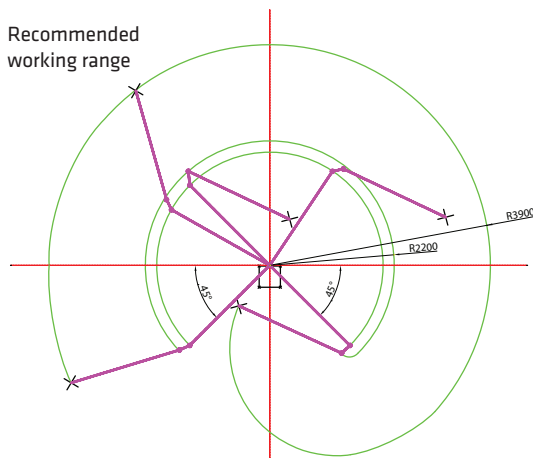

UK Distributor

**Andron Handling Limited**

Unit 7, Globe Business Park • First Avenue • Marlow • Buckinghamshire SL7 1YA • UK

telephone: +44 0845 075 8200 • e-mail: sales@andronhandling.com

www.andronhandling.com

2018-09-11

# BINAR

Improving your productivity